

# Availability Evaluation and Maintenance Policy of Data Center Infrastructure

Kádna Camboim<sup>\*†</sup>, Carlos Melo<sup>‡</sup>, Jean Araujo<sup>†</sup>, and Fernanda Alencar<sup>\*</sup>

<sup>\*</sup>Centro de Tecnologia e Geociências, Universidade Federal de Pernambuco, Recife, Brazil

<sup>†</sup>Universidade Federal do Agreste de Pernambuco, Garanhuns, Brazil

<sup>‡</sup>Centro de Informática, Universidade Federal de Pernambuco, Recife, Brazil

{kadna.camboim, jean.teixeira}@ufape.edu.br, casm3@cin.ufpe.br, fernandaalenc@gmail.com

**Abstract**—The convergence of communication networks and the demand for storage and processing capacities for large amounts of information, especially in recent years, has driven requests for everything-as-a-service and has been generating, on an increasing scale, demands for new data center constructions. However, to meet dependability attributes, the design of these infrastructures needs to consider, at least, the system’s availability to be achieved. In this paper, we evaluate the availability of a Tier 1 data center infrastructure, considering the use of blade systems. We use modeling techniques based on reliability block diagrams and stochastic Petri nets to simulate a maintenance policy encompassed at different service levels (SLA). The results show dependability metrics, focusing on the availability and maintenance of these networks. We highlight the most severe difficulties in achieving high availability when there is no component redundancy, and the intervals between maintenance are long.

**Index Terms**—Data center, availability evaluation, maintenance policy, blade server, service level agreements (SLA)

## I. INTRODUCTION

Recently, data centers have shown expressive growth in the telecommunications market, given that they are the basis of support for “everything-as-a-service” requests, i.e., applications that are supported by cloud computing. Numerous challenges related to data centers dependability needs to be overcome daily to provide adequate service levels and meet the current demand for service-oriented computing 24/7.

Considering the redundancy levels of network components, electrical and cooling systems, the *Uptime Institute* [1] presents four types of data center classification, which are used worldwide, ranging from tier 1 to 4. Thus, each tier represents a certain level of criticality to achieve availability corresponding, which vary from 99.67% (tier 1) to 99.995% (tier 4) [1]. Each additional “nine” increases the order of magnitude of availability by a factor of 10. Thus, an increase from 99.99% to 99.999% is significant and represents a ten times higher cost of investment [2].

Several factors can affect data centers’ performance, availability, reliability, growth, and economic sustainability. In this sense, many researchers have been using different approaches to deal with these issues. Below we present some works that have a more significant correlation with this research.

In [3], the authors present a fault tree to identify the dependency between the components of a blade server system. A set of Markov chain models is generated to present the

failure states and the systems’ availability. This paper served as a source to represent the MTTFs of the Blade system components. However, it differs from our study in several points, described next: 1) The study performs the modeling specifically for the blade system, and in our research, the blade system represents only the part of the critical IT load that is responsible for storing and processing data on a DC; 2) The models presented (fault tree and Markov chains) aims to represent some dependence on the components according to failure and recovery specifications. For our study, we represent these systems’ components at a high level of abstraction to compute the blade system’s MTTF, whose value is used in the subsequent models.

In [4], proposed stochastic Petri nets (SPN) and reliability block diagrams (RBD) models to evaluate data center energy infrastructures. Some scenarios were created to represent maintenance and to identify the fulfillment of service levels. Despite our research’s proximity, this paper differs from ours in the points mentioned as follows: 1) The authors do not specify the DC tier represented and present models for the electrical infrastructure. We precisely model the IT load of a tier 1 DC; 2) The authors created scenarios to represent financial losses at the expense of annual downtime. Our scenarios aim to alternate between the occurrences of preventive maintenance and the average time spent on component repairs to quantify the availability achieved in different situations.

In [5], the authors carry out evaluations of the electrical architecture of a level 3 data center to estimate costs and emissions of  $CO_2$ . They also present an energy matrix according to the energy costs of different primary sources for countries like China, Germany, the United States, and Brazil. Besides, an artificial neural network is used to predict energy consumption in the following months. Our research differs from that mentioned in the following points: 1) Despite identifying the DC class (tier 3), the authors model the electrical architecture; 2) The authors cited the use of different energy production materials to quantify the emissions of  $CO_2$  caused by DC. In contrast, we use other types of dependability metrics and SLA contracts.

In this study, we propose a set of models and maintenance policies to quantify maintenance strategies’ impact on the systems’ availability. Some scenarios are created to measure availability given the addition of component redundancy rep-

resenting the IT loads.

The remainder of this paper is organized as follows. Section II shows basic concepts about what was covered technically in this study. Section III presents the support methodology for the construction and evaluation of the conceived models, which are presented in Section IV. This last section provides the experimentation that demonstrates the feasibility of the proposed models and the results. Finally, Section V presents final considerations and future work.

## II. BACKGROUND

This section presents the fundamental concepts for a better understanding of this study.

### A. Dependability Requirements for Data Center

Currently, organizations are prioritizing more efficient projects to achieve savings in space, resources, and investment. These requirements are strongly desired, especially for data centers that aim to adopt the “green” seal - sustainable. In this sense, the choice of efficient components for all subsystems, which do more work per watt of energy [6], should be privileged. Blade center systems are an alternative for processing and storing the critical IT load that meet the requirements mentioned.

Blade servers are being widely adopted due to their modular design, which provides framework technology for multiple servers, facilitating power-sharing, cooling, and other shared services within the chassis. Integrated network switches provide additional space conservation and significant reductions in cabling [3]. Compared to server racks, blades can be more easily managed due to the density and component grouping characteristics [7].

Given the accelerated growth of the digital economy, data center projects must promote sufficient resources to meet high availability. In this sense, a range of metrics can be quantified, especially to fit them in a particular tier. For example, a tier I data center is the most basic, in which there are no redundant components or systems (N). A failure in electrical distribution can disrupt IT operations in whole or in part. Minimum availability must be 99.67%, and downtime can reach 28.8 hours per year [1].

Among the various metrics for the most different purposes is the dependability attributes that allow obtaining quantitative measures, often crucial for analyzing the services offered by different systems types. Some features commonly used in systems reliability and dependability analysis are referenced in several publications [8]–[11]. The following are those that are of interest to this research.

1) *Mean time to failure (MTTF)*: The mean exposure time between consecutive repairs (or installations) of a component and the next failure of that component. The MTTF of a system can be calculated by Equation 1.

$$MTTF = \int_0^{\infty} R(t)dt \quad (1)$$

2) *Mean time to repair (MTTR)*: The mean time to replace or repair a failed component. The logistics time associated with the repair, such as purchasing parts, mobilizing the team, is not included. MTTRs are closely related to the maintenance policy adopted and can be achieved by Equation 2.

$$MTTR = MTTF \times \frac{UA}{A} \quad (2)$$

where  $UA$  represents system downtime (Equation 3) and  $A$  represents system availability (Equation 4).

$$UA = 1 - A \quad (3)$$

3) *Availability*: Ability of the system to execute its programmed function during a specific time [9]. Availability is obtained by steady-state analysis or simulation by Equation 4.

$$A = \frac{MTTF}{MTTF + MTTR} \quad (4)$$

4) *Maintainability*: Ability of the system to undergo modifications and repairs [9]. It is described by the equation 5, where  $T$  denotes the repair time or the total downtime. This equation represents maintainability since the repair time  $T$  has a density function  $g(t)$ .

$$V(t) = P\{T \leq t\} = \int_0^t g(t)dt \quad (5)$$

Maintenance comprises any actions that should alter a system state to keep it in an operational mode (preventive maintenance) or to return it to an operational condition if it has failed (corrective maintenance) [12].

5) *Reliability Block Diagram (RBD)*: It is a formalism used to calculate dependability metrics such as availability, reliability, and maintainability. RBDs models contain an entry and an output. Between them, the system may consist of block structures in series, parallel, bridge, or blocks k-out-of-n [10].

A serial block diagram requires that each component is functioning to have operational status. The Equation 6 obtains its reliability of the system.

$$R_s(t) = \prod_{i=1}^n R_i(t) \quad (6)$$

where  $R_i(t)$  corresponds to the reliability of the block  $b_i$  at time  $t$ . Similarly, other probabilistic metrics can be calculated for structures in series.

A parallel block diagram requires that only one component is working [13]. The reliability of  $n$  blocks connected in parallel is obtained by Equation 7.

$$R_P = 1 - \prod_{i=1}^n (1 - R_i(t)) \quad (7)$$

where  $R_i(t)$  corresponds to the reliability of the block  $b_i$  at time  $t$ .

Blocks *k - out - of - n* represent structures in which the subsystem can work if  $k$  or more components are in operational state [14].

6) *Stochastic Petri Net (SPN)*: They marked with a finite number of places and transitions are isomorphic Markov chains [15]. Isomorphism of an SPN model with a Markov chain is obtained from the reduced reachability graph, which is given by eliminating volatile states and label the arcs with the rates of the timed transitions and weights of immediate transitions. Time (stochastic delays) and probabilistic choices are essential aspects of a performance evaluation model. We adopt the usual association of delays and weights with transitions [16] in this paper and adopt the extended SPN definition given in [17].

### III. METHODOLOGY

The methodology used to design this work considers some steps presented in a generic way to describe the activities to obtain results in each particular phase. Figure 1 shows the stages of this study.

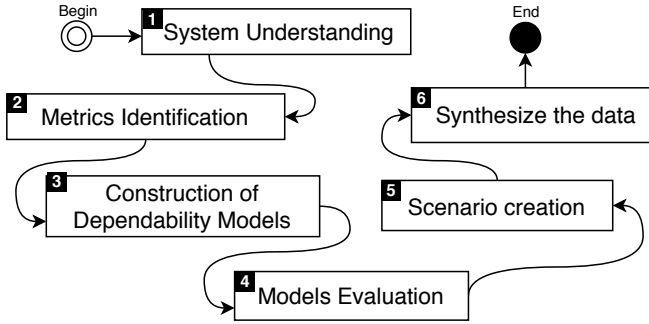

Fig. 1. Methodology.

1) **System Understanding** - In this phase, we identified problems pertinent to data center projects until the software to support this project. This paper considers a basic tier 1 data center, which does not have much redundancy of components or subsystems (electrical and cooling) and has the challenge of achieving/providing a minimum availability of 99.67%. We use Mercury Tool 4.8 to model the critical IT load components, considering some network components and blade chassis for data storage and processing.

2) **Metrics Identification** - In this phase, we identify the input and output metrics. Some possible output parameters are system availability, reliability, and MTTF.

3) **Construction of Dependability Models** - Corresponds to the RBD and SPN models' construction to represent the system components and the proposed maintenance policy. We perform the modeling in a hybrid and hierarchical way, which introduces combinatorial models and models based on states.

4) **Models Evaluation** - After performing the modeling, we can perform the evaluations in search of the metrics of interest.

6) **Scenario creation** - To validate the results, we present some scenarios. In this work, the specific objective is to present how maintenance affects availability. The proposed policy defines preventive maintenance to avoid errors in the system's operation or restore it after serious failures.

7) **Synthesize the data** - We check and synthesize the results to identify possible improvements in the metrics, models, or scenarios.

### IV. DEPENDABILITY MODELS

In this section, we present the RBDs and SPN models designed to perform this work.

#### A. Definition of Parameters and Proposed Models

It is important to note that the components used to represent the models in this work and the models themselves are generic enough to be adapted for different needs. Furthermore, they are independent of the manufacturer's brand. We seek to represent models and scenarios according to the definition of use in real data centers [1], [2]. Although a data center project consists of several subsystems, we only represent the network's part. Figure 2 shows the DC network layers. Some models can represent only one, two, or all of the layers that are presented.

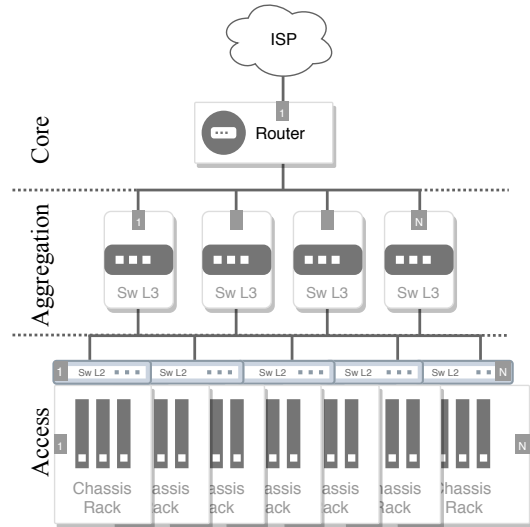

Fig. 2. Network Layers.

Table I shows which components are used in each RBD model and the quantity referring to them. Take one unit of the mentioned component when there is no indication of the amount. We also show the MTTR for each element.

TABLE I  
DEFINITION OF RBDs MODELS.

Models	Components	MTTR (h)
1st	Base blade, CPU, DIMMs, HD, Fiber channel card, Ethernet card	4 for each
2nd	Midplane, Software, Power Suply (4), Fiber Switch (2), Ethernet switch (2), Blower (2), Blade server (14)	4 for each
3rd	Router, Fiber link, Chassis (3)	8, 8, 4
4th	Router, Fiber link, Chassis (5)	8, 8, 4
5th	Router, Fiber link, Switchs (4), Ethernet link (20), Chassis (20)	8 for each

TABLE II  
COMPONENTS MTTF.

Component	MTTF (h)	Reduction	Source	
Base Blade	220,000		[3]	
CPU	500,000	X		
Memory Bank (DIMMs)	480,000			
Hard Disk Drive	200,000			
Fiber Channel Daughter Card	260,000	X		
Ethernet Daughter Card	1,240,000	X		
Midplane	310,000			
Software	17,520			
Power Supply	670,000			
Fiber Switch	320,000			
Ethernet Switch	120,000			
Blower	620,000	X		
Blade Server	54,700.42			1st RBD Model
Router	96,154	X		[19]
Fiber Link	980,200	X	[20]	
Switch	88,684.60	X	[21]	
Ethernet Link	240,000	X	[20]	
Chassis	15,139.63		2nd RBD Model	

For the RBDs models, we use the MTTFs that are shown in Table II. We obtained all components' MTTFs of source shown in the 4th column. Specific components had their MTTF value reduced. We applied a reduction factor of 0.8 because the MTTF was supplied by the manufacturer (even some components obtained from [3] suffered this reduction because they had an unusually high MTTF. The paper cited was made in partnership with the manufacturer). This reduction can be applied at a 95% confidence level [18]. Look at the 3rd column to see which components have undergone this reduction.

The first RBD model corresponds to the representation of the blade server components. Figure 3 presents this model, whose components and MTTR is specified in the second line of Table I (1st Model). We consider four hours of repair for each component due to the ease of replacement in case of failure. All blocks are connected in series. For models designed with series-type blocks, all components must be in operation because if one component fails, the entire system will fail.

The second RBD model represents the components of a chassis composed of 14 blade servers. We represent this

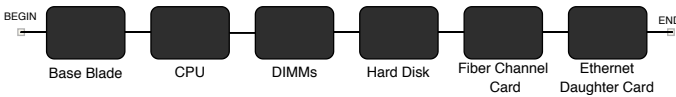

Fig. 3. 1st RBD model - Blade server.

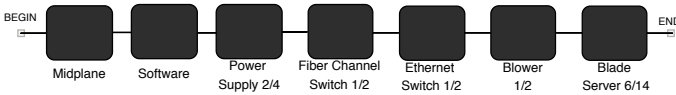

Fig. 4. 2nd RBD model - Blade chassis.

amount because it is quite common among the different manufacturers of these systems; however, we can find variations with chassis from 10 to 16 blade servers. Figure 4 presents this model, whose components and MTTR is specified in the third line of Table I (2nd Model). We also consider four hours of repair for the same reason cited for the first model. This model encompasses the access layer (See Figure 2). For this model, we use  $K$ -out-of- $N$  blocks with a series structure. These blocks are used to represent a minimum number of components that need to work. For example, in Figures 4 we use this type of block to say that at least 2 of 4 energy sources need to work (note the other subsequent components).

After modeling the chassis, we performed the evaluation, and we were able to identify the systems' MTTF, which will be used as an input metric for the next models that represent different network configurations for a tier 1 data center. We represent three different networks for DC Tier 1, considering that only a small redundancy could be added. Thus, the next three RBDs models represent the mentioned networks.

Figure 5-a) shows the third model, which represents the first network, consisting of the minimum required to represent a small data center. The components and MTTR are specified in the fourth line of Table I (3rd Model). This model aggregates the access and core layers due to the small number of components (See Figure 2). Therefore, for this model, we use serial and parallel blocks. For models that use blocks in parallel, only one component (from the parallel port) needs to work.

Figure 5-b) shows the fourth RBD model, that represents the second network with two additional chassis. The components and MTTR are specified in the fifth line of Table I (4th Model). This model aggregates the same layers as the third model. For the third and fourth models, we eliminate L3 switches' need due to the chassis itself having them.

Figure 5-c) shows the IT infrastructure for the fifth RBD model with a few more components and a certain redundancy level. The components and MTTR are specified in the fifth line of Table I (5th Model). We consider that at least 15 out of 20 Ethernet links and chassis must work for the system to remain operational. Therefore, for this model, we use serial, parallel, and  $k$ -out-of- $n$  structural blocks. This latest RBD model encompasses all network layers (See Figure 2). The MTTFs achieved by analyzing these models are used as input metrics in the SPN model. In this sense, we evaluate the SPN model often to find the availability achieved in each network and observe the maintenance effects in the network's availability. The SPN model was designed to represent the proposed maintenance policy. We consider the intervals between these maintenances every 720, 360, and 168 hours. Also, we also adopt different repair times for each care, varying between -50% and +50% of the MTTR (4, 8, and 12 hours). We consider nine scenarios with different service levels, which can be found in SLAs contracts, to check if the intervals and repair times determined for the maintenance are sufficient for these networks to achieve the minimum availability suggested for tier 1.

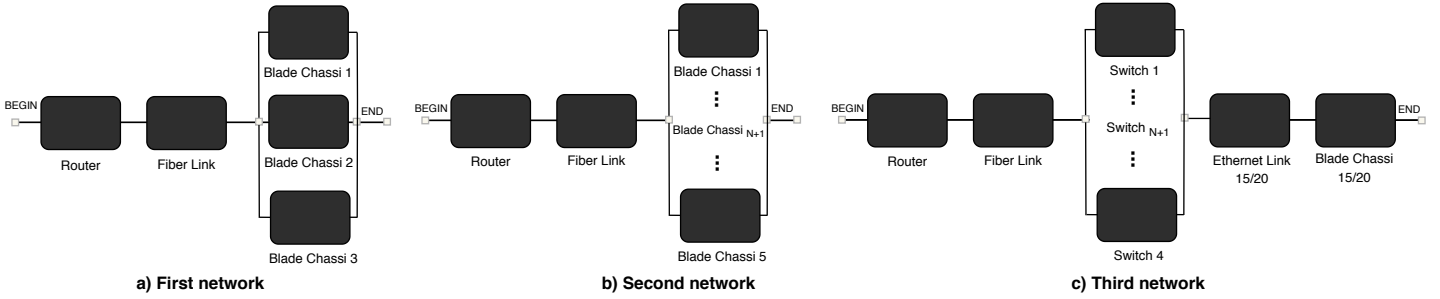

Fig. 5. 3rd, 4th and 5th RBDs models - Tier 1 data center networks.

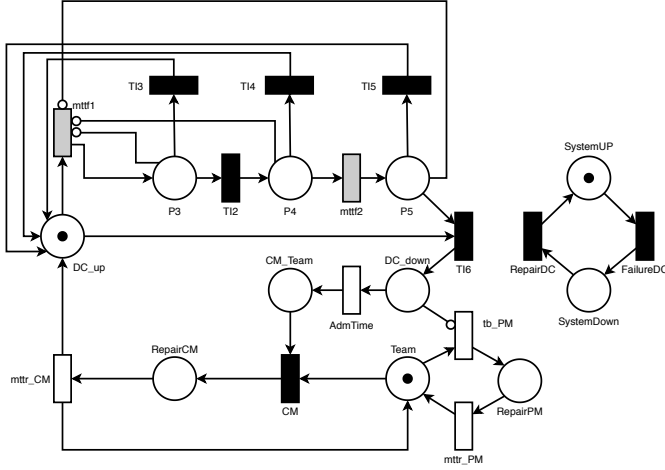

Fig. 6. SPN model - Maintenance policy.

Figure 6 presents the SPN model proposed, which consists of two sub-nets, one that represents the data center states ( $DC\_Up$  and  $DC\_Down$ ) and the maintenance actions, and the other is a sub-net that checks the general condition of the system. A team carries out preventive and corrective maintenance. The token assigned to the *Team* place represents the availability of its.

The states  $P3$ ,  $P4$ , and  $P5$  and their respective immediate transitions represent an Erlang distribution to indicate critical moments, which need repairs but did not cause the DC to stop. The sub-net suggests the need for preventive repair from the guard expression ( $\#DC\_up = 0$ ) in the immediate transition *FailureDC*, and a token is placed in the *SystemDown* place. If the repair is not carried out, a mark will be assigned to the location  $DC\_down$  (in the original SPN), indicating the unavailability of the data center as well as the need for corrective repair. After DC's fallen, we consider two hours of administrative time to carry out the procedures for activating maintenance, calling up the team, and separating replacement components. This time is represented by the exponential transition *AdmTime*. Suppose the team performed the repair, the sub-net, from the expression of guard ( $\#DC\_up = 1$ ) in the immediate transition *RepairDC*, checks if the system has been restored. If so, a mark is assigned to the location *SystemUP* again.

## B. Result Analysis

Table III shows some metrics obtained from the RBD model evaluations. Note that a minimum of three “nines” (99.9%) has been achieved for the five models’ availability. The MTTF obtained from the first RBD is used in the second, which is used in the other three network models. Table IV presents nine classes of SLA that aim to represent different management categories, which we classify as “poorly managed” - when a maintenance occurs every 30 days (720 hours), “managed” - every 15 days (360 hours), and the “well managed” - every seven days (168 hours). We decided to compare the availability achieved with that suggested for a tier 1 data center (99.672%) for our experiment.

The results presented for the nine SLA classes show a variation in the availability value achieved for each scenario. Some statements can be stated. The first is that we can infer that with the MTTFs of the components used, considering the proposed maintenance policy, it is impossible to achieve high availability, as suggested for high-performance data centers.

TABLE III  
DEPENDABILITY METRICS - RESULTS.

Model	Evaluation Period (8760 h)		
	Availability (%)	Reliability (%)	MTTF System (h)
1st	99.99268	85.20	54,700.42
2nd	99.97588	58.61	15,139.63
3rd	99.99086	82.80	22,592.76
4th	99.99086	88.99	27,366.36
5th	99.99086	6.04	5,062.47

TABLE IV  
AVAILABILITY ACHIEVED WITH THE SPN MODEL.

SLAs	Interval (h)	Repair (h)	Availability (%)		
			1st Net	2nd Net	3rd Net
1	720	12	94.11	94.82	78.81
2		8	94.50	95.12	78.82
3		4	94.28	95.53	78.13
4	360	12	96.51	97.38	88.99
5		8	96.89	97.45	87.97
6		4	97.47	97.79	87.16
7	168	12	98.73	98.72	93.28
8		8	98.68	99.13	93.26
9		4	98.87	99.09	93.80

The highest achieved availability was that of SLA 8, 2nd Net, with 99.13%. If we compare with the availability suggested for tier 1 data center, no scenario could reach it.

The second statement is that, for the third scenario, that despite being a complete network represented, still presenting a relatively low number of components; the levels of availability are merely unacceptable as a result of the lack of redundancy of the main components, such as the edge router, which was not represented due to the impossibility of redundancy of Internet providers for tier 1 DC. We can conclude that when the intervals between preventive maintenance are longer (e.g., 720 hours), availability has the worst result in all networks (1, 2, and 3 SLAs). For operational guarantees, the data center design must provide for maintenance policies whose intervals are sufficient to avoid disruption of services.

We could have represented other alternatives to provide higher availability results. The first would be to have shorter intervals between maintenance. The second would be to have lower MTTRs. Furthermore, the third would be to use higher MTTFs. However, note that the latter alternative would hardly change the value of availability. Because if we consider the software component (See Table II), which has the lowest MTTF of the second RBD model, presenting two years for failure, it is the most critical component for the system (2nd model RBD). There is not much that can be done, given that it is usual to find references of up to three years for software failure, but no more. Thus, we emphasize how preventive maintenance and the time spent on repairs play a fundamental role in guaranteeing data center network availability.

## V. FINAL REMARKS

This paper proposed a set of models to evaluate a data center's availability, considering the impact of maintenance routines over this dependability attribute. We aimed to comply with nine different SLAs that were also proposed to attend to the tier 1 data center's needs, where there is no redundancy of Internet providers and energy operators, but they must still provide 99.67% availability of services. The results showed the difficulty of achieving high availability when the system's MTTFs are relatively low, and when preventive maintenance is dependent on long intervals. It is essential to highlight some limitations of this research: we try to be faithful to the MTTF values found for real components. However, due to the variety of manufacturers brands, these values can differ significantly. Thus, our results do not represent this plurality. Another issue that deserves to be highlighted is the confusion between the terms MTTF and MTBF. The first is commonly found for non-repairable items, but its use is more common in reliability analysis because the modeling properties are static. The second is usually supplied in a datasheet of components presented by manufacturers, but the values generally presented are exaggeratedly high due to the performance of stress tests to be carried out in controlled environments, which in practice can be quite different from reality. The second limitation is related to using a hierarchical approach, which can address possible errors due to reusing new models' metrics. Our work's third limitation

is the minimum of components to form a tier 1 data center network. Note that due to the characteristics, we can consider a data center as a research laboratory within a university, for example. However, due to the lack of redundancy, it does not even show three nines in availability. As proposals for future work, we intend to carry out the same evaluations for a Tier 2 data center, with redundancy levels from the Internet provider to the IT load. Besides, we will also consider energy factors in these scenarios.

## REFERENCES

- [1] W. P. Turner IV, J. PE, P. Seader, and K. Brill, "Tier classification define site infrastructure performance," *Uptime Institute*, vol. 17, 2006.
- [2] P. S. Marin, "Data centers-desvendando cada passo: conceitos, projeto, infraestrutura física e eficiência energética," *São Paulo: Érica*, 2011.
- [3] W. E. Smith, K. S. Trivedi, L. A. Tomek, and J. Ackaret, "Availability analysis of blade server systems," *IBM Systems Journal*, vol. 47, no. 4, pp. 621–640, 2008.
- [4] G. Callou, E. Sousa, P. Maciel, E. Tavares, C. Araujo, B. Silva, N. Rosa, M. Marwah, R. Sharma, A. Shah *et al.*, "Impact analysis of maintenance policies on data center power infrastructure," in *2010 IEEE international conference on systems, man and cybernetics*. IEEE, 2010, pp. 526–533.
- [5] J. Ferreira, G. Callou, A. Josua, and P. Maciel, "Estimating the environmental impact of data centers," in *2018 IEEE 17th International Symposium on Network Computing and Applications (NCA)*. IEEE, 2018, pp. 1–4.
- [6] G. Schulz, *The green and virtual data center*. CRC Press, 2016.
- [7] K. Leigh and P. Ranganathan, "Blades as a general-purpose infrastructure for future system architectures: Challenges and solutions," *HP Labs Tech. Rep. HPL-2006-182*, 2007.
- [8] C. Heising *et al.*, "Ieee recommended practice for the design of reliable industrial and commercial power systems," *IEEE Inc., New York*, 2007.
- [9] K. Trivedi, D. S. Kim, A. Roy, and D. Medhi, "Dependability and security models," in *Design of Reliable Communication Networks, 2009. DRCN 2009. 7th International Workshop on*, oct. 2009, pp. 11 –20.
- [10] W. Kuo and M. J. Zuo, *Optimal reliability modeling: principles and applications*. John Wiley & Sons, 2003.
- [11] P. R. M. Maciel, K. Trivedi, R. Mathias JR, and D. Kim, *Dependability Modeling In: Performance and Dependability in Service Computing: Concepts, Techniques and Research Directions*. Pennsylvania, USA.: Ed. Hershey: IGI Global, 2010.
- [12] W. R. Blischke and D. N. P. Murthy, *Case studies in reliability and maintenance / edited by Wallace R. Blischke, D.N. Prabhakar Murthy*. John Wiley, Hoboken, NJ :, 2003. [Online]. Available: <http://www.loc.gov/catdir/toc/wiley031/2002191075.html>
- [13] K. Trivedi and M. Malhotra, "Reliability and performance techniques and tools: A survey," in *Messung, Modellierung und Bewertung von Rechenund Kommunikation systemen*, 1993, pp. 27 – 48.
- [14] M. Xie, K.-L. Poh, and Y.-S. Dai, *Computing System Reliability: Models and Analysis*. Springer, 2004.
- [15] T. Murata, "Petri nets: Properties, analysis and applications," *Proceedings of the IEEE*, vol. 77, no. 4, pp. 541–580, 1989.
- [16] R. Gaeta and M. A. Marsan, "SwN analysis and simulation of large knockout atm switches," in *International Conference on Application and Theory of Petri Nets*. Springer, 1998, pp. 326–344.
- [17] R. German, "Markov regenerative stochastic petri nets with general execution policies: supplementary variable analysis and a prototype tool," *Performance Evaluation*, vol. 39, no. 1-4, pp. 165–188, 2000.
- [18] D. J. Smith, *Reliability, maintainability and risk: practical methods for engineers*. Butterworth-Heinemann, 2017.
- [19] Cisco 4000 Family Integrated Services Router Data Sheet, Cisco, 2020. [Online]. Available: [https://www.cisco.com/c/en/us/products/collateral/routers/4000-series-integrated-services-routers-isr/data\\_sheet-c78-732542.html](https://www.cisco.com/c/en/us/products/collateral/routers/4000-series-integrated-services-routers-isr/data_sheet-c78-732542.html)
- [20] Mean Time Between Failures (MTBF), Extreme, 2020. [Online]. Available: <https://www.extremenetworks.com/support/mean-time-between-failures/>
- [21] Cisco Catalyst 4500-X Series Fixed 10 Gigabit Ethernet Aggregation Switch Data Sheet, Cisco, 2020. [Online]. Available: [https://www.cisco.com/c/en/us/products/collateral/switches/catalyst-4500-x-series-switches/data\\_sheet\\_c78-696791.html#cid=ossdc000283](https://www.cisco.com/c/en/us/products/collateral/switches/catalyst-4500-x-series-switches/data_sheet_c78-696791.html#cid=ossdc000283)